

Excavator Checklist

Date: _____ Time: _____ Location: _____

Qualified person(s) responsible for jobsite: _____

Are existing utilities marked: Yes No If so, have they been located?: _____

Depth of excavation: _____ Width of excavation top: _____

Width of excavation bottom: _____

Employee's in excavation: Yes No If yes, to what depth: _____

Ladder in excavation: Yes No

Ramp used: Yes No

Means of protection (circle): Sloping Shoring Sheeting Trench Box & Plates: _____

Consult MITA Trench Safety Handbook for Shoring Designs

Spoils back 2': Yes No

Water in excavation: Yes No If yes, controlled by what means _____

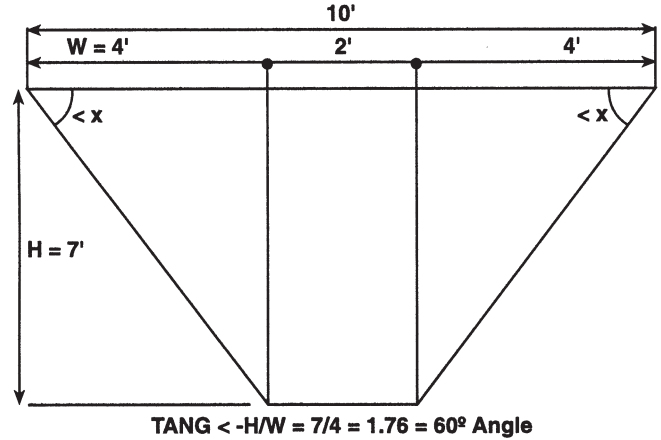
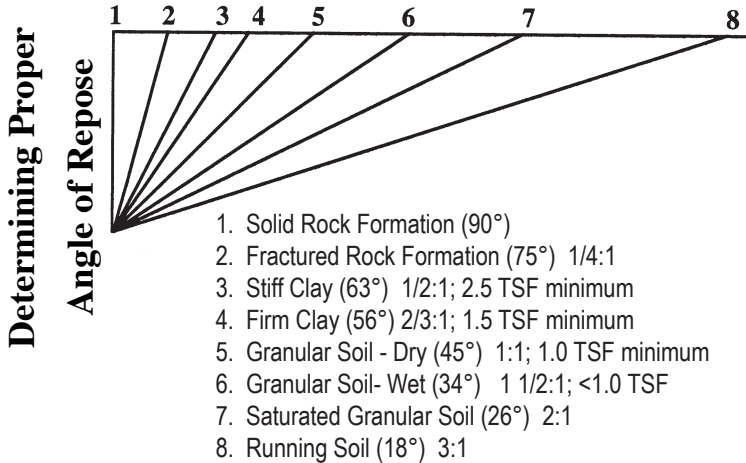

Penetrometer readings: Top _____ Middle _____ Bottom _____

Type of soil: _____

If a trench box was used, how high off the bottom of excavation. _____

Size & type of utility installed: _____

Overhead lines present: Yes No If yes, how close: _____

Designated spotter used: Yes No Who: _____

Manholes covered: Yes No

Annual inspection of excavator available: Yes No

Danger swing stickers in place: Yes No

Fire extinguisher in all cabbed equipment: Yes No

Back-up alarm(s) functional: Yes No

Chains, slings, and wire rope checked for deficiencies: Yes No

Safety latches on lifting hooks: Yes No

All employees wearing hard hats: Yes No

Monitor on site to test confined spaces: Yes No

Are barricades and signs needed: Yes No

(draw a diagram of what was in place on the back of this form)

Comments: _____

Signed: _____

Signed: _____

Safety Manager

Qualified Person